

BYD Battery-Box Technical Training



AGENDA

1 | ABOUT BYD

2 | BYD BATTERY-BOX

3 | Battery-Max Lite

4 | Installation Tips





ABOUT BYD



Group Revenue

2021 Annual Turnover

\$33.5 billion USD

Compound Annual Growth Rate

55%

■ Operating Income (million USD)

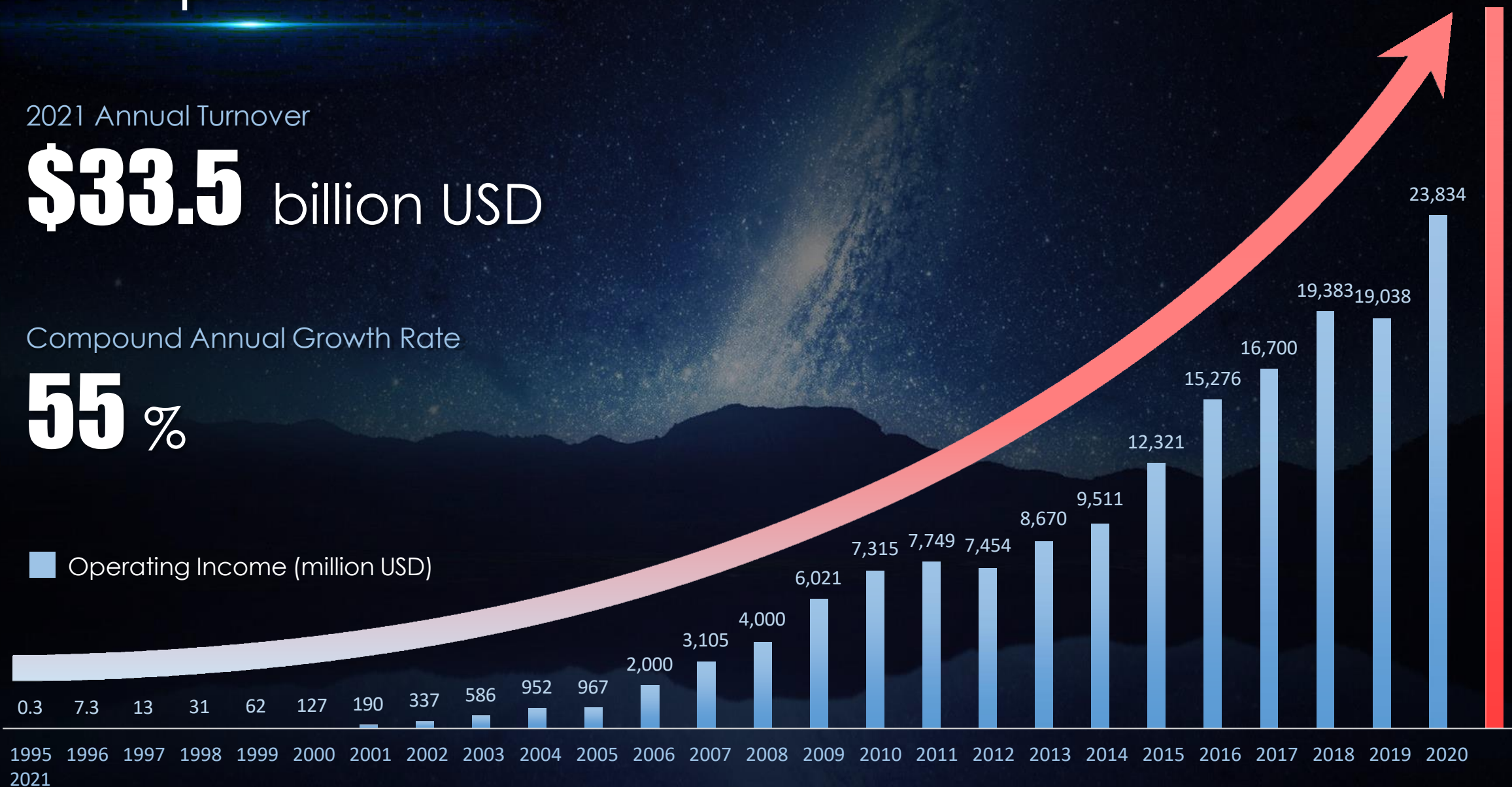



Global Footprint

Over **400** cities in over **90** countries & regions in **6** continents*

NORTH AMERICA

Canada
United States
Mexico

EUROPE

Netherlands	Norway	Portugal
United Kingdom	Denmark	France
Belgium	Germany	Sweden
Spain	Ireland	Finland
Italy	Israel	
Romania	Hungary	

ASIA PACIFIC

Chinese Mainland	Malaysia
Taiwan, China	Singapore
Hong Kong, China	Australia
Macau, China	New Zealand
Japan	French Polynesia
South Korea	Mongolia
Philippines	Vietnam
Indonesia	Myanmar
Nepal	Cambodia
India	Pakistan
Thailand	Bangladesh
Laos	Bhutan
Sri Lanka	New Caledonia

LATIN AMERICA

Colombia	Cuba
Ecuador	Bolivia
Peru	Paraguay
Brazil	Bahamas
Uruguay	Guatemala
Chile	Curacao
Panama	Jamaica
Argentina	Costa Rica
Antigua	Dominican Republic
Barbados	

MIDDLE EAST & AFRICA

Jordan	South Africa
Egypt	Kenya
Lebanon	Mauritius
Tunisia	Zimbabwe
Bahrain	Qatar

* As of Q1, 2022



About BYD

4 Main Industries

30+
Industrial Parks

40+
Branch Offices

About **290k**
Employees*



Electronics



Auto



Renewable
Energy



Rail Transit



* As of Q1, 2022



Full Market EV Strategy

The first and only company in the world to provide full market new energy vehicle solutions. The only auto company to master the core technologies of the entire EV industrial chain including motors, electronic controls, batteries, and semiconductors.

7

Conventional Applications

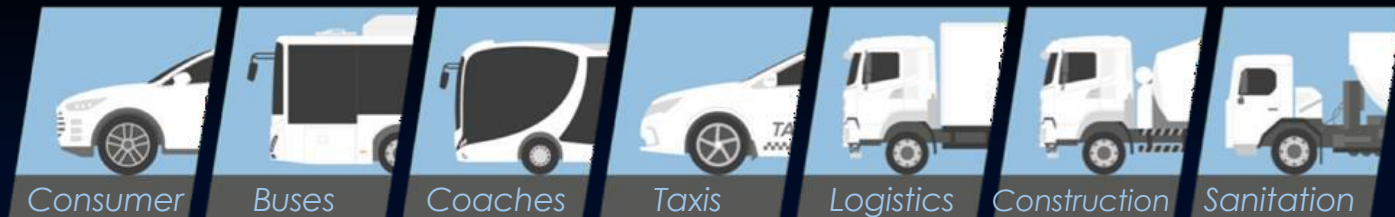

+

4

Specialized Applications





Auto

No.1 NEV Sales in China
for nine consecutive years*



Green Transportation Strategy



Rail Transit
to solve **Traffic Congestion**

Electric Vehicles
to solve **Air Pollution**

Renewable Energy



A pioneer in providing a zero emission energy ecosystem

from **power generation**
to **storage**, to **usage**.

Since 2008 BYD's solar power and energy storage products have been exported to 6 continents, more than 20 countries, and more than 90 cities.*

* As of Q1, 2022

BYD UK Clavhill 6MW/6Wh
Photovoltaic Storage
Integration Project



Battery Production Capacity

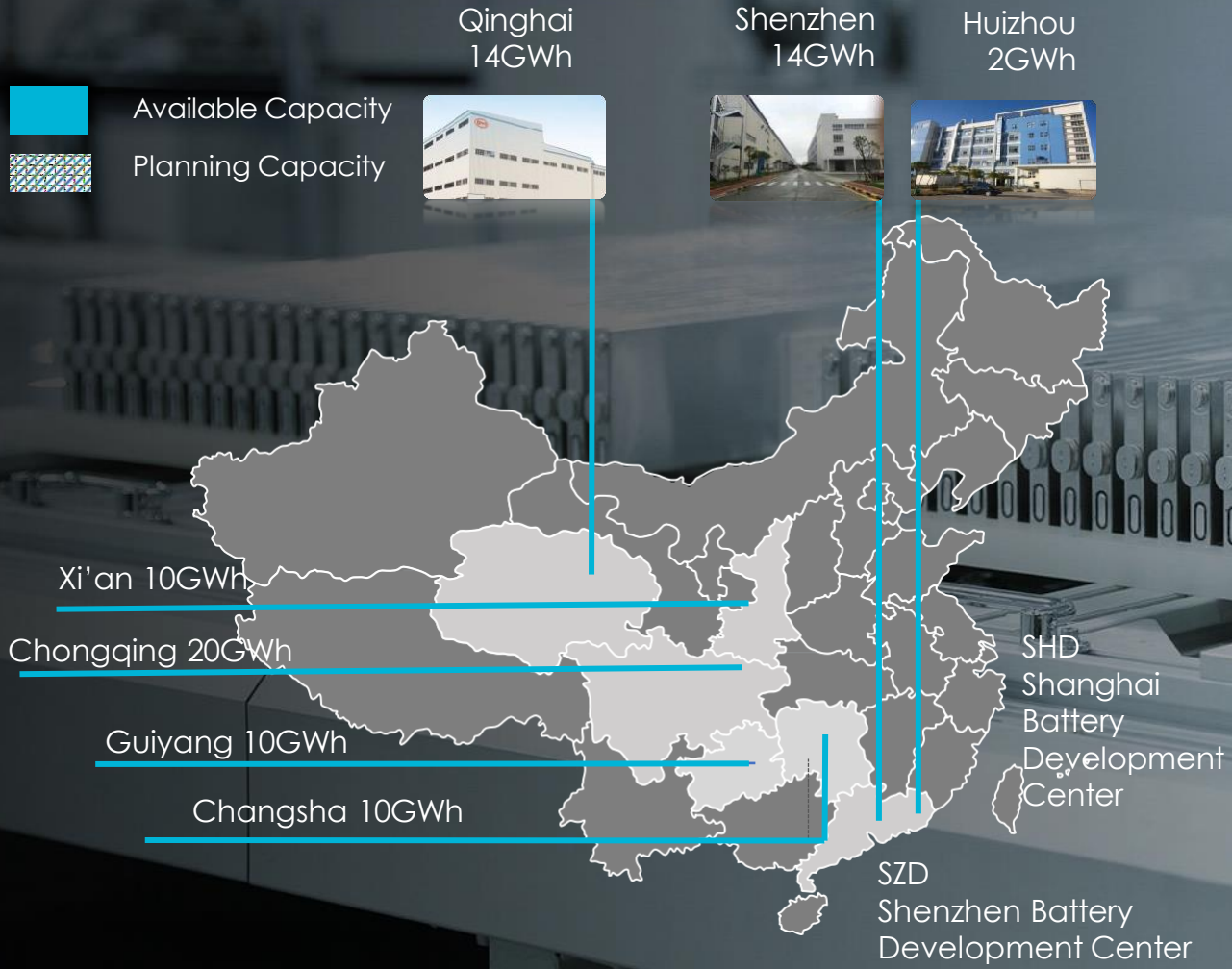

2021-2025 BYD battery capacity planning

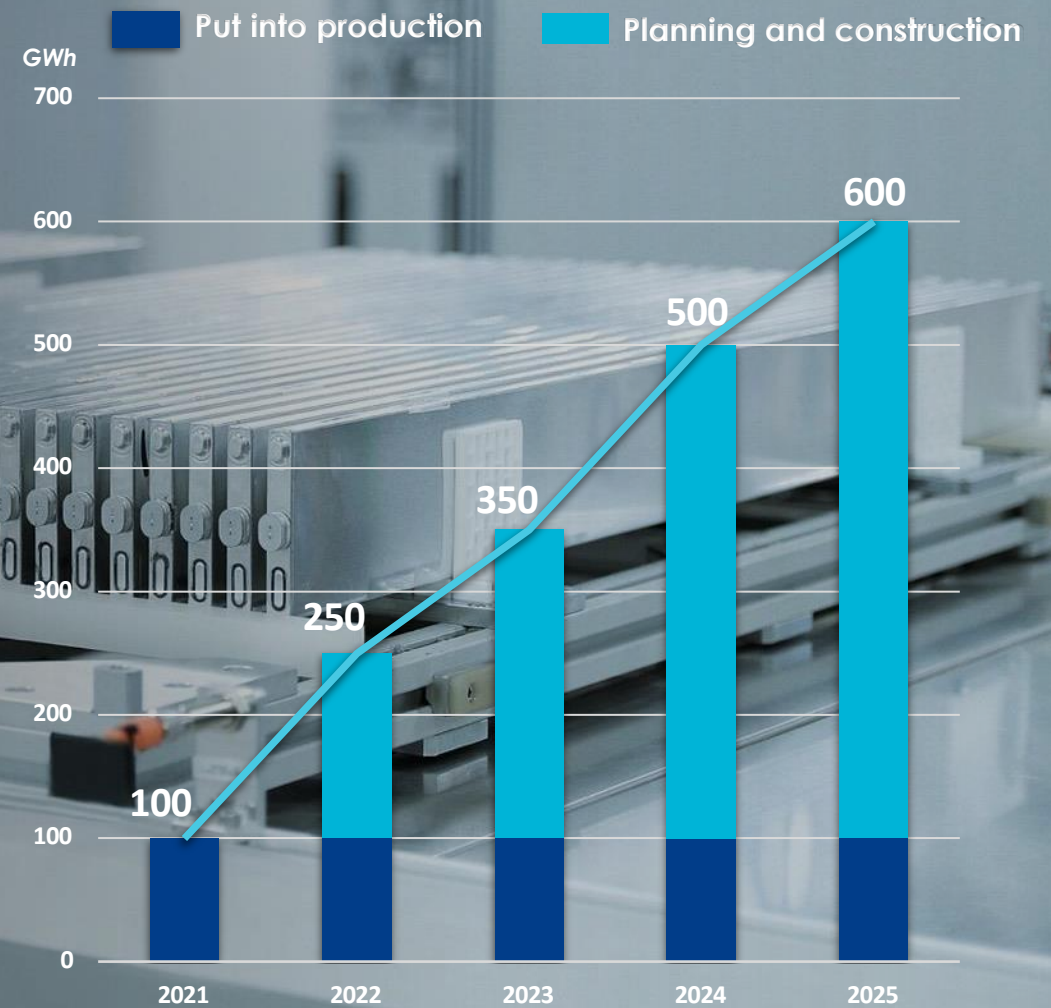



BYD Battery End To End Industry Chain Layout

Mineral resources
development

Process Development

BMS R&D
Manufacture

System R&D
Manufacture

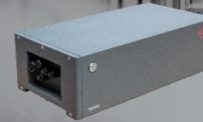

Material Research
Manufacture

Cell R&D
Manufacture

Module R&D
Manufacture

Recycle



BYD BATTERY-BOX

BYD BATTERY-BOX EVOLUTION

GEN 1



GEN 2



GEN 3



Product: Battery-Box Pro
Released: 2015

Product: Battery-Box HV
Released: 2017

Product: Battery-Box Premium HV
Released: 2020



BYD BATTERY-BOX PREMIUM LINEUP

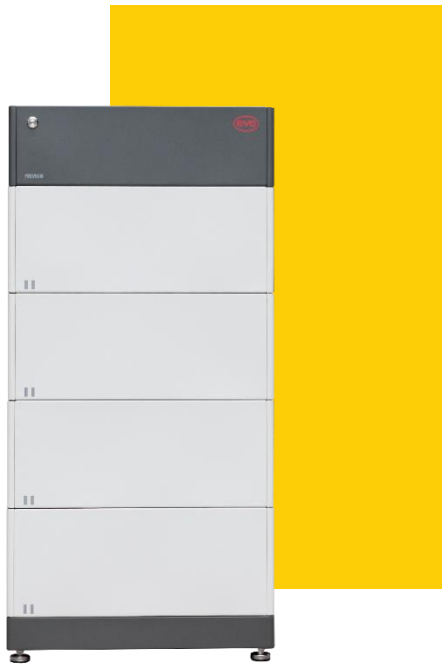

HVS/HVM



LVS



LVL

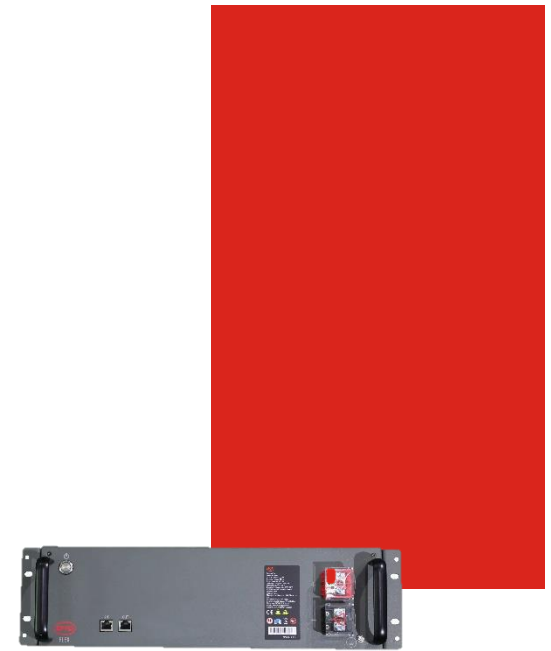

LV Flex



BYD BATTERY-BOX PREMIUM LINEUP

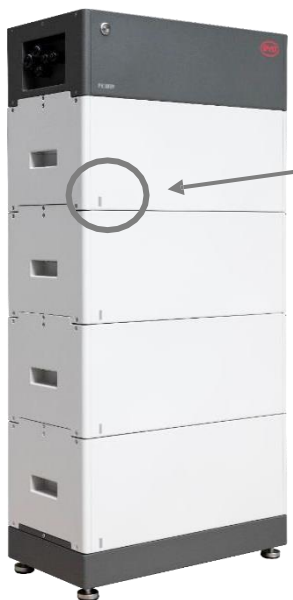

1 strip

HVS

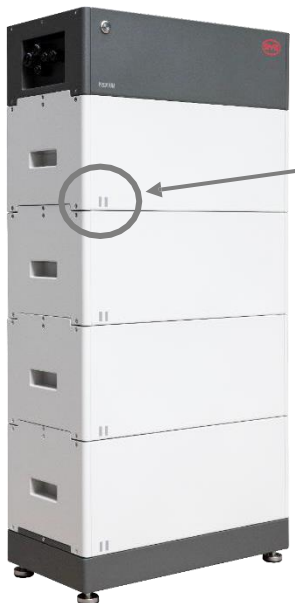

2 strips

HVM



Button

LVS



LVL

IP20

IP55

LV Flex
3U Design



BATTERY
BOX



HVS



HVS



HVS 5.1



HVS 7.7



HVS 10.2







HVS 12.8



3×HVS 12.8



INVERTER COMPATIBILITY

	 HVS 5.1	 HVS 7.7	 HVS 10.2	 HVS 12.8
Battery Module	HVS (2.56 kWh, 102.4 V, 38 kg)			
Number of Modules	2	3	4	5
Usable Energy [1]	5.12 kWh	7.68 kWh	10.24 kWh	12.8 kWh
Max Output Current [2]	25 A	25 A	25 A	25 A
Peak Output Current [2]	50 A, 3 s	50 A, 3 s	50 A, 3 s	50 A, 3 s
Nominal Voltage	204.8 V	307.2 V	409.6 V	512 V
Operating Voltage	160~230.4 V	240~345.6 V	320~460.8 V	400~576 V
Dimensions (H/W/D)	762x585x298 mm	995x585x298 mm	1228x585x298 mm	1461x585x298 mm
Weight	91 kg	129 kg	167 kg	205 kg



Fronius Symo Hybrid
/ GEN24 Symo & Primo



Sungrow HV Hybrid



SMA SBS 5.0/
2.5(only HVS)



GoodWe ET / EH



HVS COMPATIBLE INVERTER LIST

BYD BATTERY-BOX PREMIUM HVS&HVM COMPATIBLE INVERTER LIST - V2.5

[DE] BYD Battery-Box Premium HVS / HVM kompatible Wechselrichterliste

[ES] Lista de Inversores Compatibles con Battery-Box Premium HVS/HVM

[IT] Lista di Configurazione Minima e degli Inverter Compatibili con BYD Battery-Box Premium HVS/HVM



Inverter [DE] Wechselrichter [ES] Inversores [IT] Inverter	Module Quantity [DE] Modulanzahl [ES] Cantidad de módulo [IT] Quantità moduli		Minimum Firmware Version						
	HVS	HVM	Single Tower [DE] Einzelturm / [ES] torre única / [IT] torre singola			Parallel Connection [DE] Parallelschaltung / [ES] conexión paralela / [IT] connessione parallela			
			Inverter	Battery-Box		Inverter	Battery-Box		
	BMU	BMS		BMU	BMS				
Fronius	Symo Hybrid	-	3-8	1.16.6-1	3.13	3.19	1.16.7-1	3.14	3.20
	Symo GEN24 Plus	2-4	4-8	1.9.7-0	3.13	3.19	1.10.5-0	3.14	3.20
	Primo GEN24 Plus	2-3	4-7	1.11.6-0	3.15	3.21	1.11.6-0	3.15	3.21
	Note: Parallel connection is not possible for Fronius Inverters in the configuration: 3 x HVM 22.1 [DE] Parallelschaltung ist mit Fronius Wechselrichtern nicht möglich für die Konfiguration: 3 x HVM 22.1 [ES] La conexión en paralelo no es posible para los inversores Fronius en la configuración: 3 x HVM 22.1 [IT] Il collegamento in parallelo non è possibile per gli inverter Fronius nella configurazione: 3 x HVM 22.1								
GoodWe	ET/BT	2-5	4-8	ARM 11	3.13	3.19	ARM 11	3.13	3.19
	EH/BH	2-4	3-8						
KOSTAL	Plenticore Plus 3.0	2-5	4	01.42	3.13	3.19	01.42	3.13	3.19
	Plenticore Plus 4.2/5.5/7.0/8.5/10.0	2-5	4-8						
	Plenticore BI 5.5-13, 5.5-26	2-5	5-8						
	Plenticore BI 10.0-26	3-5	5-8						
	Piko MP Plus 1.5-1, 2.0-1, 2.5-1	2-3	3-4						
	Piko MP Plus 3.0-1, 3.0-2, 3.5-1, 3.5-2, 4.6-2, 5.0-2	2-5	3-8						

SMA	Sunny Boy Storage 2.5	2-4	-	3.11.06R	3.15	3.21	3.11.06R	3.15	3.21
	Sunny Boy Storage 3.7	2-4	3-8	For HVS: 3.11.03R	3.13	3.19	-	-	-
	Sunny Boy Storage 5.0	2-4	3-8						
	Sunny Boy Storage 6.0	2-4	3-8	For HVM: 3.11.10R					
	Note: For SBS 3.7 / 5.0 / 6.0 no parallel connection - check inverter manual how to connect up to three batteries [DE] Für SBS 3.7 / 5.0 / 6.0 keine Parallelschaltung - siehe Wechselrichterhandbuch, wie man bis zu drei Batterien anschließt [ES] Para SBS 3.7 / 5.0 / 6.0 sin conexión en paralelo disponible: consulte el manual del inversor sobre cómo conectar hasta tres baterías [IT] Per SBS 3.7 / 5.0 / 6.0 nessuna connessione parallela è disponibile - controllare il manuale dell'inverter come collegare fino a tre batterie								
Sungrow	SH5.0/6.0/8.0/10RT	3-5	4-8	ARM,V11_V01_B MDSPV11_V01_B	3.13	3.19	ARM,V11_V01_B MDSPV11_V01_B	3.13	3.19
KACO	Blueplanet hybrid 6.0 - 10.0 TL3	2-4	3-8	5.8.6.3.7	3.13	3.19	5.8.6.3.7	3.13	3.19
Ingeteam	ISS 1Play 3TL M / 6TL M	2-4	3-8	ABH1007_F	3.15	3.22	ABH1007_F	3.15	3.22
	Note: Only compatible with BCU produced since 1st October, 2020. [DE] Nur kompatibel mit BCU, die seit dem 1. Oktober 2020 produziert wurden [ES] Solo compatible con BCU fabricados desde el 1 de octubre de 2020. [IT] Compatibile solo con BCU prodotte dal 1 ottobre 2020.								
Solis	RHI-3P(5-10)K-HVES-5G	2-4	3-8	V090037	3.16	3.24	-	-	-
	Note: Parallel Connection not released yet [DE] Parallelschaltung noch nicht freigegeben [ES] Conexión paralela aún no aprobada [IT] Connessione parallela non ancora rilasciata								



Download link:

<https://www.bydbatterybox.com/downloads>



HVM



HVM

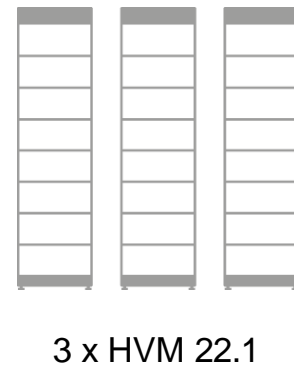
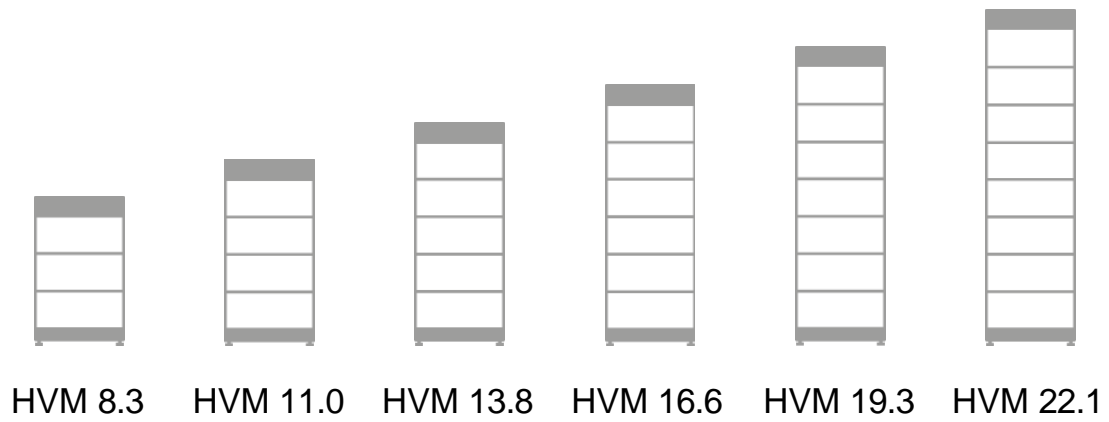

INVERTER COMPATIBILITY

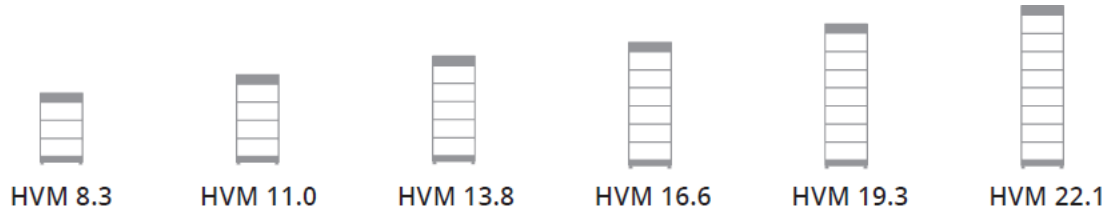

	HVM (2.76 kWh, 51.2 V, 38 kg)					
Battery Module						
Number of Modules	3	4	5	6	7	8
Usable Energy [1]	8.28 kWh	11.04 kWh	13.80 kWh	16.56 kWh	19.32 kWh	22.08 kWh
Max Output Current [2]	40 A	40 A	40 A	40 A	40 A	40 A
Peak Output Current [2]	75 A, 3 s	75 A, 3 s	75 A, 3 s	75 A, 3 s	75 A, 3 s	75 A, 3 s
Nominal Voltage	153 V	204 V	256 V	307 V	358 V	409 V
Operating Voltage	120~173 V	160~230 V	200~288 V	240~345 V	280~403 V	320~460 V
Dimensions (H/W/D)	995 x 585 x 298 mm	1228 x 585 x 298 mm	1461 x 585 x 298 mm	1694 x 585 x 298 mm	1927 x 585 x 298 mm	2160 x 585 x 298 mm



Fronius Symo Hybrid
/ GEN24 Symo & Primo



Sungrow HV Hybrid



SMA SBS 5.0/
2.5(only HVS)



GoodWe ET / EH



LVS



LVS



LVS 4.0



LVS 8.0



LVS 12.0



LVS 16.0



LVS 20.0



LVS 24.0



16 x LVS 16.0



INVERTER COMPATIBILITY (ON & OFF GRID)

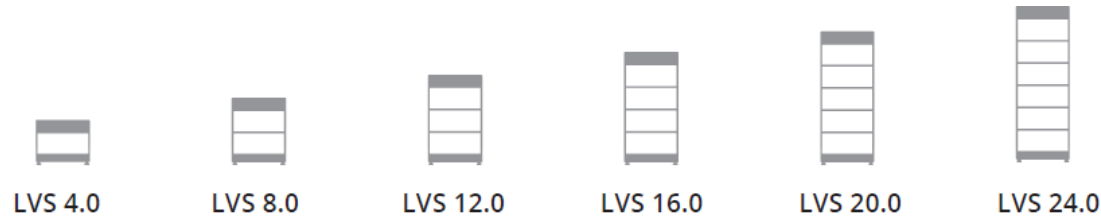

Battery Module	LVS (4 kWh, 51.2 V, 45 kg)					
Number of Modules	1	2	3	4	5	6
Usable Energy [1]	4 kWh	8 kWh	12 kWh	16 kWh	20 kWh	24 kWh
Max Cont. Output Current [2]	65 A	130 A	195 A	250 A	250 A	250 A
Peak Output Current [2]	90 A, 5 s	180 A, 5 s	270 A, 5 s	360 A, 5 s	360 A, 5 s	360 A, 5 s
Dimensions (H/W/D)	528 x 650 x 298 mm	761 x 650 x 298 mm	994 x 650 x 298 mm	1227 x 650 x 298 mm	1460 x 650 x 298 mm	1693 x 650 x 298 mm
Weight	64 kg	109 kg	154 kg	199 kg	244 kg	289 kg
Nominal Voltage	51.2 V					
Operating Voltage	40-57.6 V					
Operating Temperature	-10 °C to +50°C					



SMA



Victron



Selectronic



GoodWe



Studer





LVL



LVL



LVL 15.4



2 x LVL 15.4



64 x LVL 15.4



INVERTER COMPATIBILITY (ON & OFF GRID)



LVL15.4 (2021)

Number of Modules	2
Usable Energy [1]	15.36 kWh
Max Cont. Output Current [2]	250 A
Peak Output Current [2]	375 A, 5 s
Dimensions (H/W/D)	660 x 650 x 575 mm
Weight	168 kg
Nominal Voltage	51.2 V
Operating Voltage	40-57.6 V
Operating Temperature	-10 °C to +50°C



SMA



Victron



Selectronic



GoodWe



Studer





LV Flex



LV Flex



1 x LV Flex



4 x LV Flex



64 x LV Flex



INVERTER COMPATIBILITY (ON & OFF GRID)



LV Flex



Usable Energy [1]	5.0 kWh
Max Cont. Output Current [2]	70 A
Peak Output Current [2]	105 A, 5 s
Dimensions (H/W/D)	132x 482 x 525 mm
Weight	47 kg
Nominal Voltage	51.2 V
Operating Voltage	43.2 -57.6 V
Operating Temperature	-10 °C to +50°C
Battery Cell Technology	Lithium Iron Phosphate (cobalt-free)

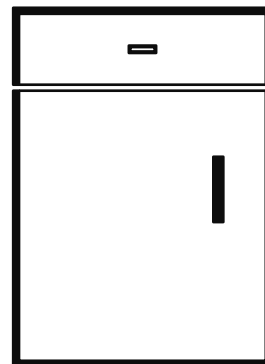

IP20 Cabinet is Available!



HIGHLY FLEXIBLE FOR INSTALLATIONS

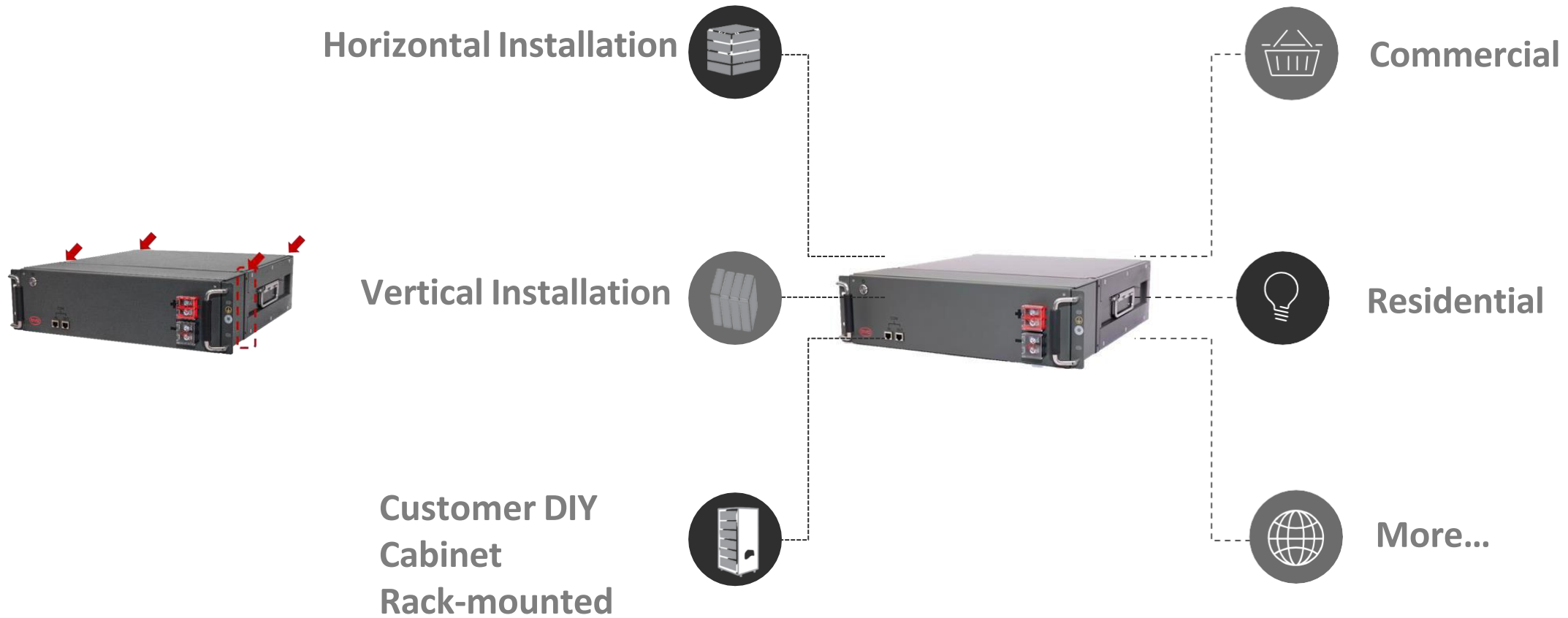



BYD BATTERY-MAX LITE

ONE FOR ALL



Flexible Size Options

Extendable battery modules

MODULES

CAPACITY

4	30kWh
6	45kWh
8	60kWh
10	75kWh
12	90kWh



Parameter

BYD Battery-Max Lite



	LITE 30	LITE 37.5	LITE 45	LITE 52.5	LITE 60	LITE 67.5	LITE 75	LITE 82.5	LITE 90
Battery Module	LITE Module (7.5 kWh, 76.8 V, 65 kg)								
Number of Modules	4	5	6	7	8	9	10	11	12
Usable Energy [1]	30 kWh	37.5 kWh	45 kWh	52.5 kWh	60 kWh	67.5 kWh	75 kWh	82.5 kWh	90 kWh
Nominal Voltage	307 V	383 V	460 V	537 V	614 V	691 V	767 V	844 V	921 V
Operating Voltage	259 ~ 355 V	324 ~ 444 V	389 ~ 532 V	453 ~ 621 V	518 ~ 710 V	583 ~ 799 V	648 ~ 888 V	712 ~ 976 V	777 ~ 1065 V
Weight	660 kg	725 kg	790 kg	855 kg	920 kg	985 kg	1050 kg	1115 kg	1180 kg
Dimensions (H/W/D)	2100 x 1100 x 1400 mm								
Max Output Current [2]	100 A								
Peak Output Current [2]	170 A, 3s								
Operating Temperature	-20 °C to +50°C								
Battery Cell Technology	Lithium Iron Phosphate (cobalt-free)								
Communication	CAN / RS485(Modbus TCP)								

Flexible Working Conditions



IP 55 Outdoor Protection



-20~55 ° C AC Temperature



Wide Application & Scenarios



Wide Application & Scenarios

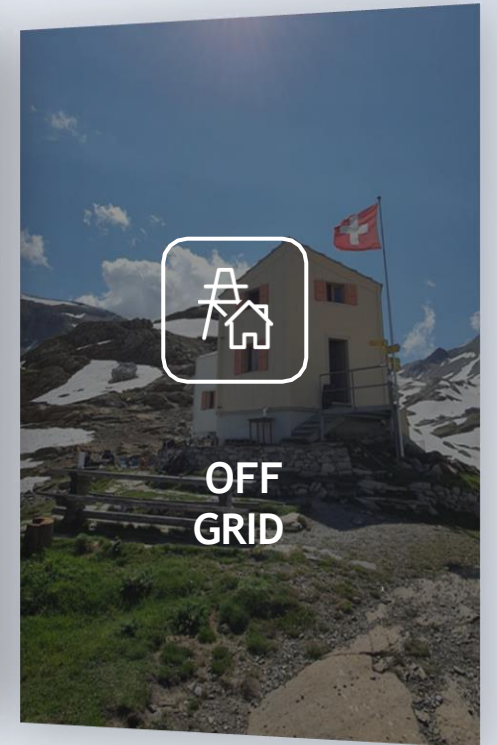

OPEN INTERFACE

Open BMS Protocol, Easy Integration.

Open BMS Protocol



Battery-Max Lite

Energy System Network

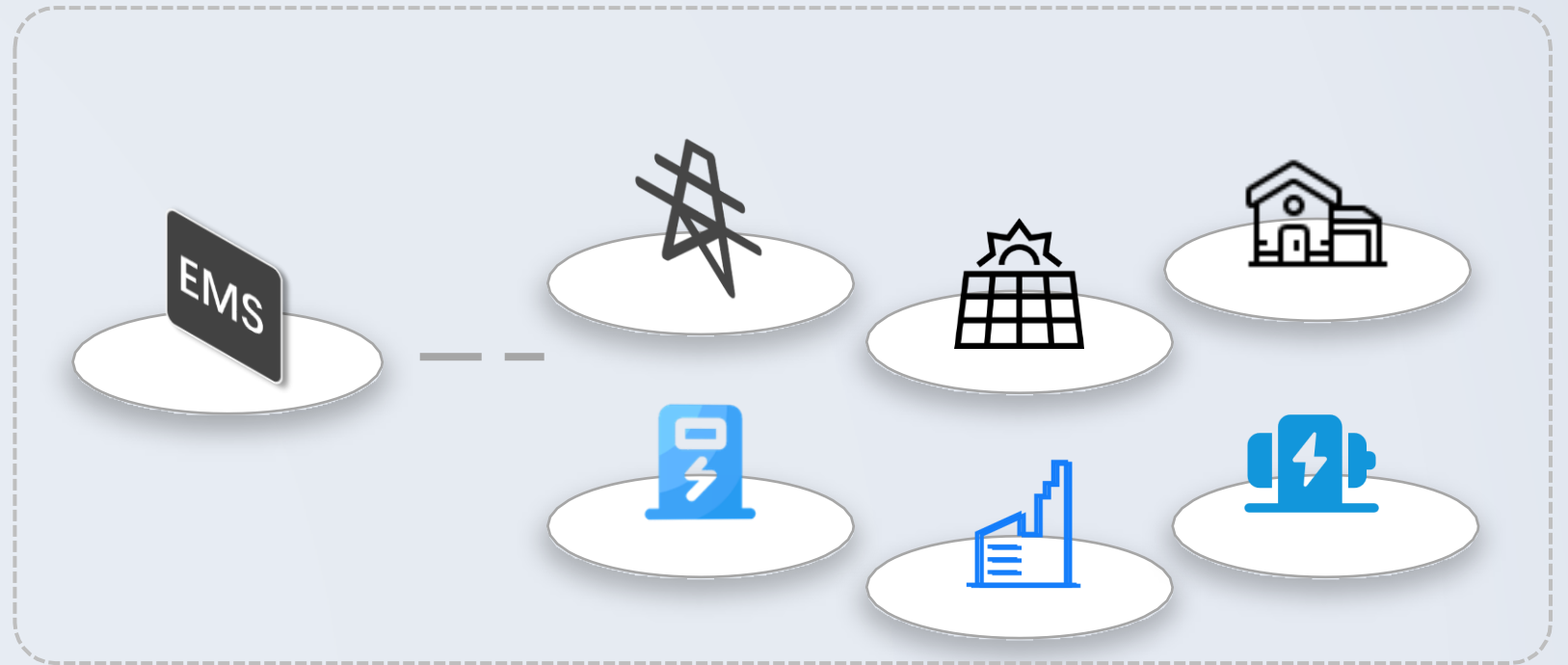

ONE FOR ALL

Wide Compatibility for Flexible Inverters



Professional Battery (DC)



Professional Inverters (AC)



**Flexible size
and power**



**Flexible Applications
and functions**

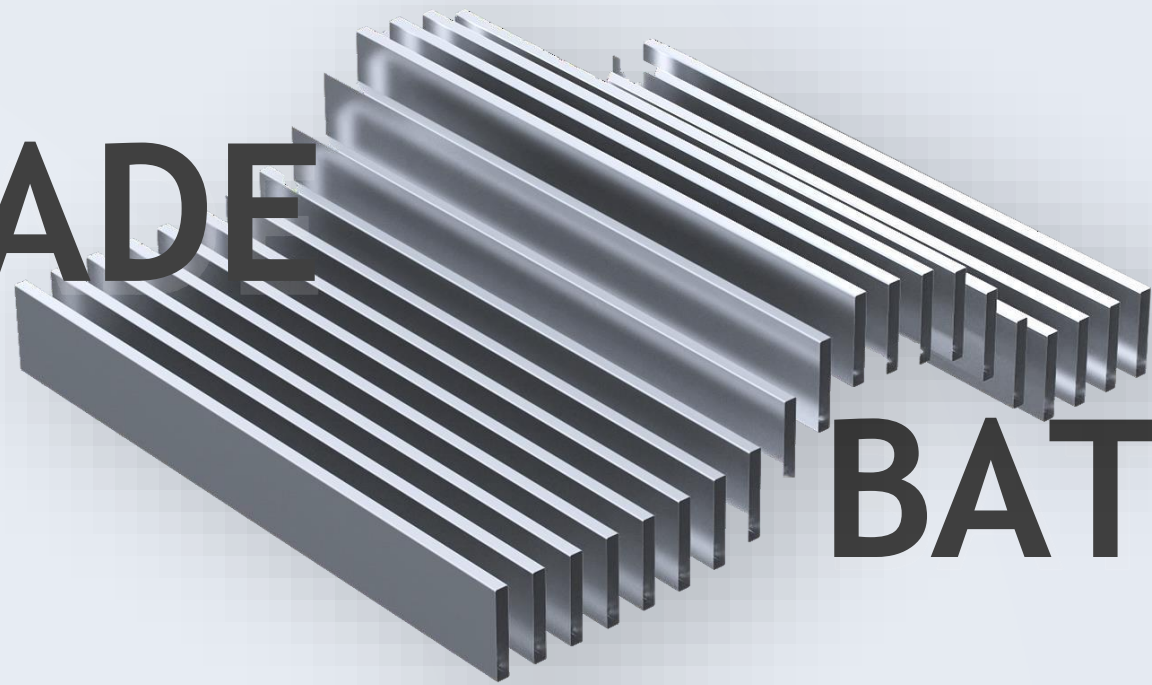

**Customized
for project**

A 3D rendering of several parallel, rectangular battery cells, known as blade cells, arranged in a perspective view. The cells are dark grey with a metallic sheen and are stacked slightly offset from each other to show depth. They are positioned behind the main title text.

BLADE BATTERY

BYD LFP Battery Technology



ULTRA-SAFE

The only battery in the world passed
Nail Penetration Test

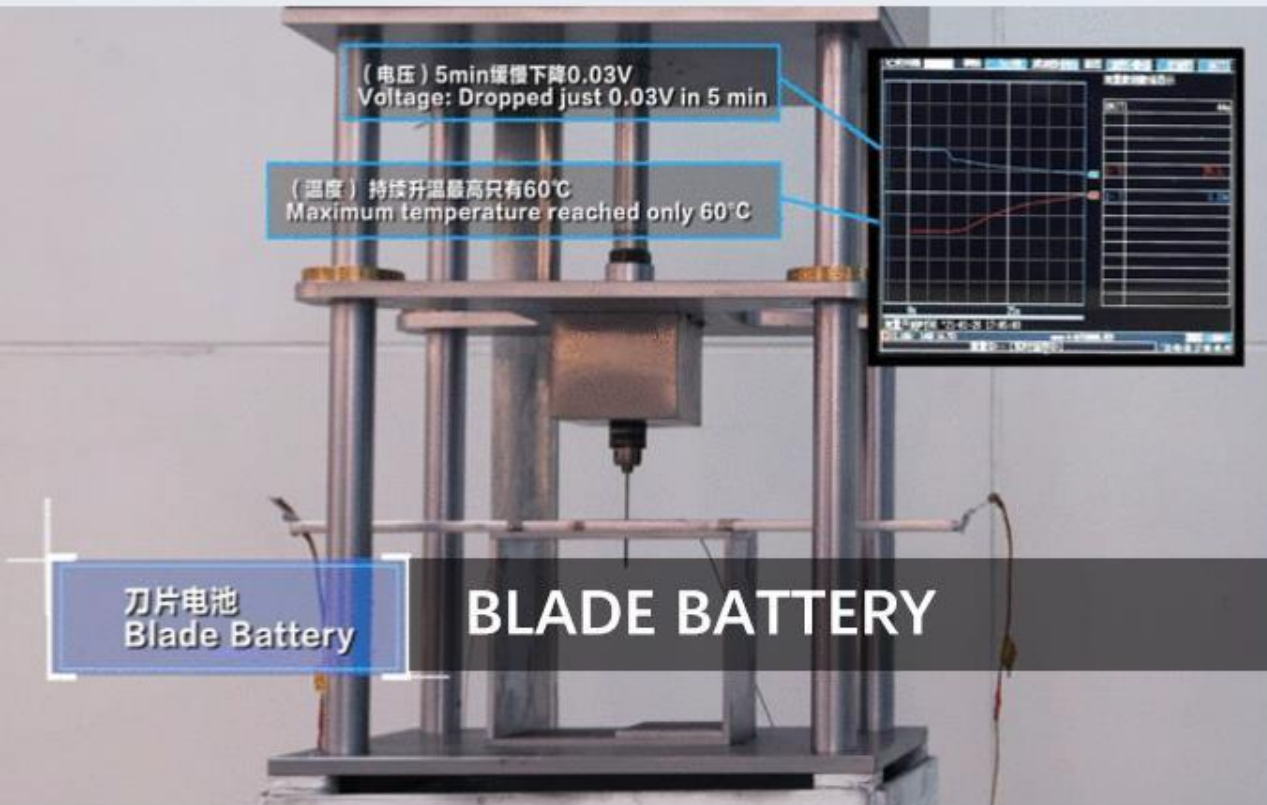



SYSTEM PROTECTION

3 extra protections on system level



Fire Supression
System



Smoke
Detection

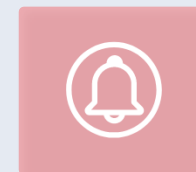

Emergency
Shutdown

Easily extend the size up to **5.7MWh**

Flexible capacity for your project



Uninterrupted Maintenance Control

Independent working of every unit, Seamless operation of entire cluster.

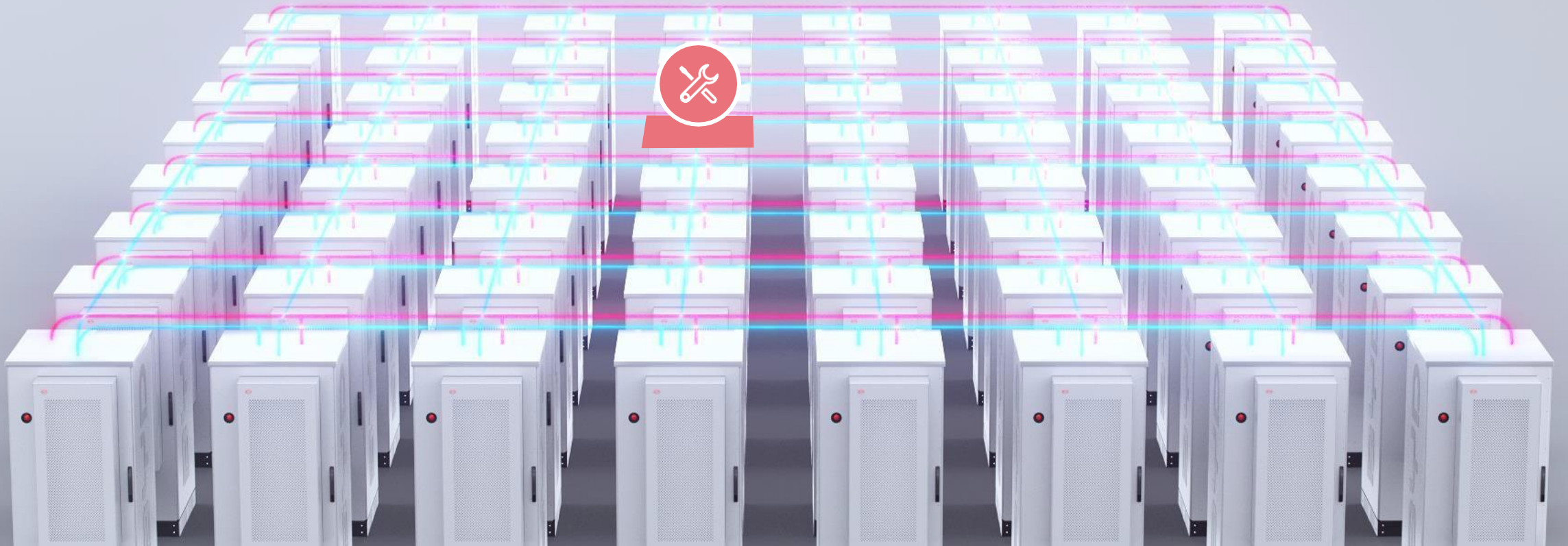



BATTERY-BOX FAMILY

**ONE
FOR
ALL**

**FLEXIBLE
SIZE**



**INTELLEGEN
T
PARALLEL**



**EASY TO
INSTALL**



**OPEN
INTERFACE**



**SEAMLESS
MAINTENANCE**



BLADE BATTERY



SELLING POINTS



BYD BATTERY-BOX ACHIEVEMENT

TOP 1 Brand Awareness

From EUPD Research 2020, BYD is the most well known battery storage manufacturer among the battery systems owners

Source: EUPD Research

Battery storage – Unaided brand awareness (2/2)

BYD is the most well known battery storage manufacturer among the owners of battery storage systems installed in 2020.

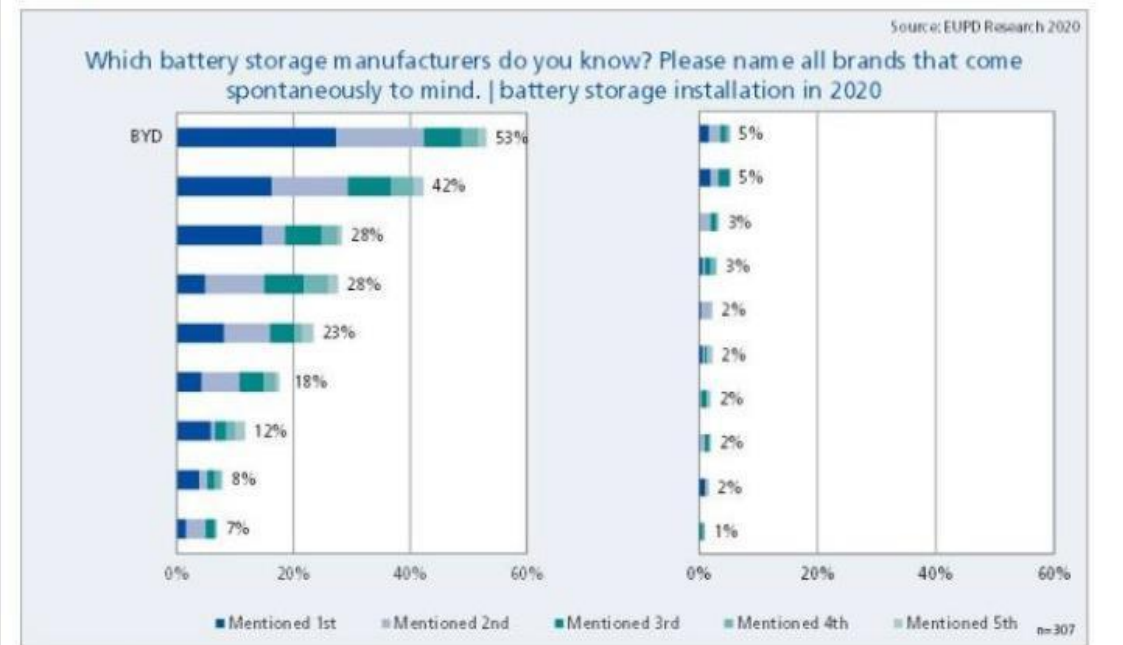

EUPD Research

SOURCE: PUBLICLY AVAILABLE EUPD RESEARCH REPORT



BYD BATTERY-BOX ACHIEVEMENT

Installer Favorite ESS Brand in Germany

TOP Choice
From Installer Partners

Source: PV magazine

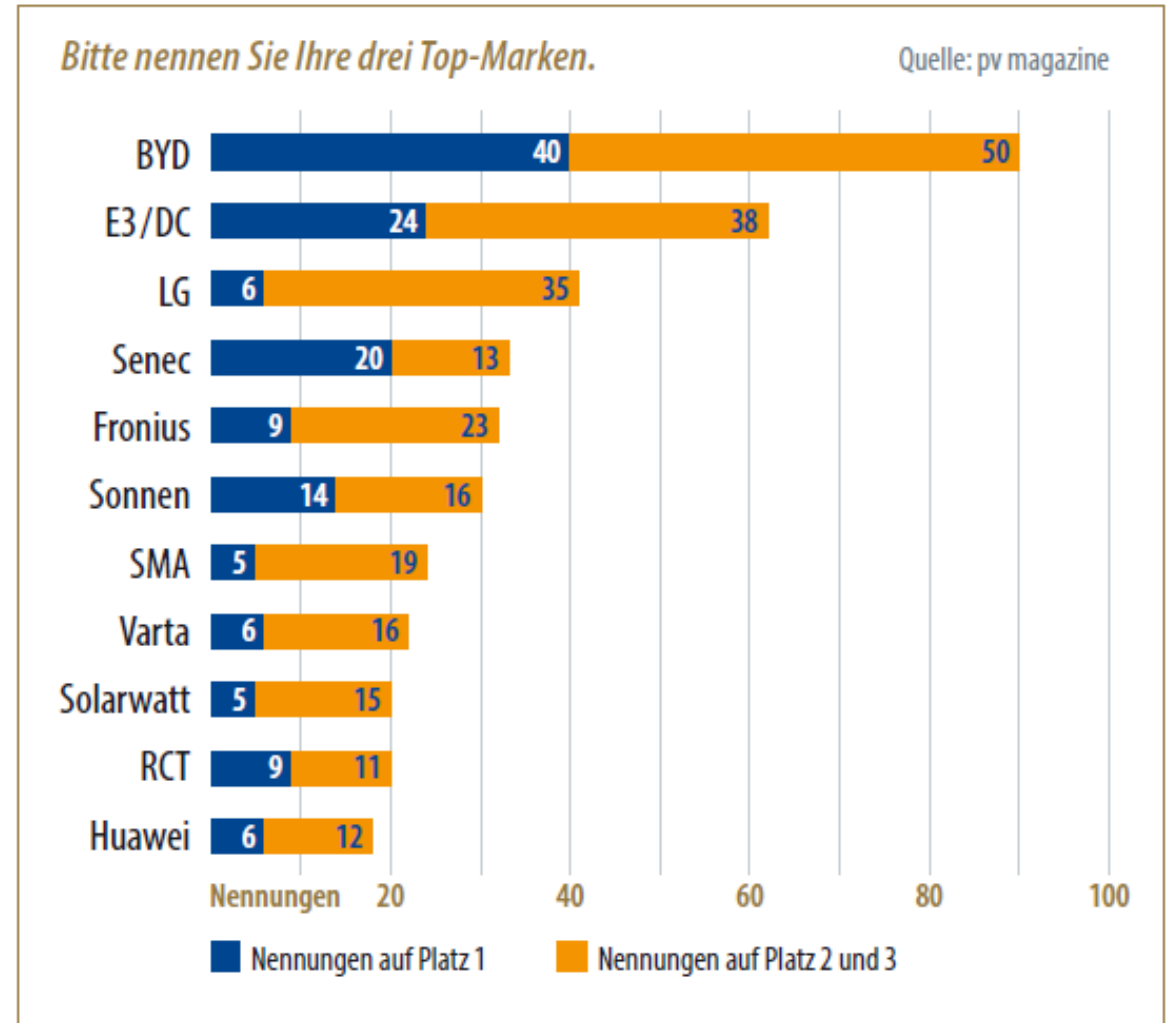

Grafik 4: Nach den Gründen gefragt, rangieren „Kompatibilität mit verschiedenen Wechselrichtern“ und „gutes Gesamtkonzept“ vorn.

<https://www.pv-magazine.de/2021/07/02/die-3-top-heimspeichermarken-der-installateure-sind-byd-vor-e3-dc-und-lg/>



BYD BATTERY-BOX ACHIEVEMENT

Energy Storage Inspection HTW BERLIN

5-YEAR BEST

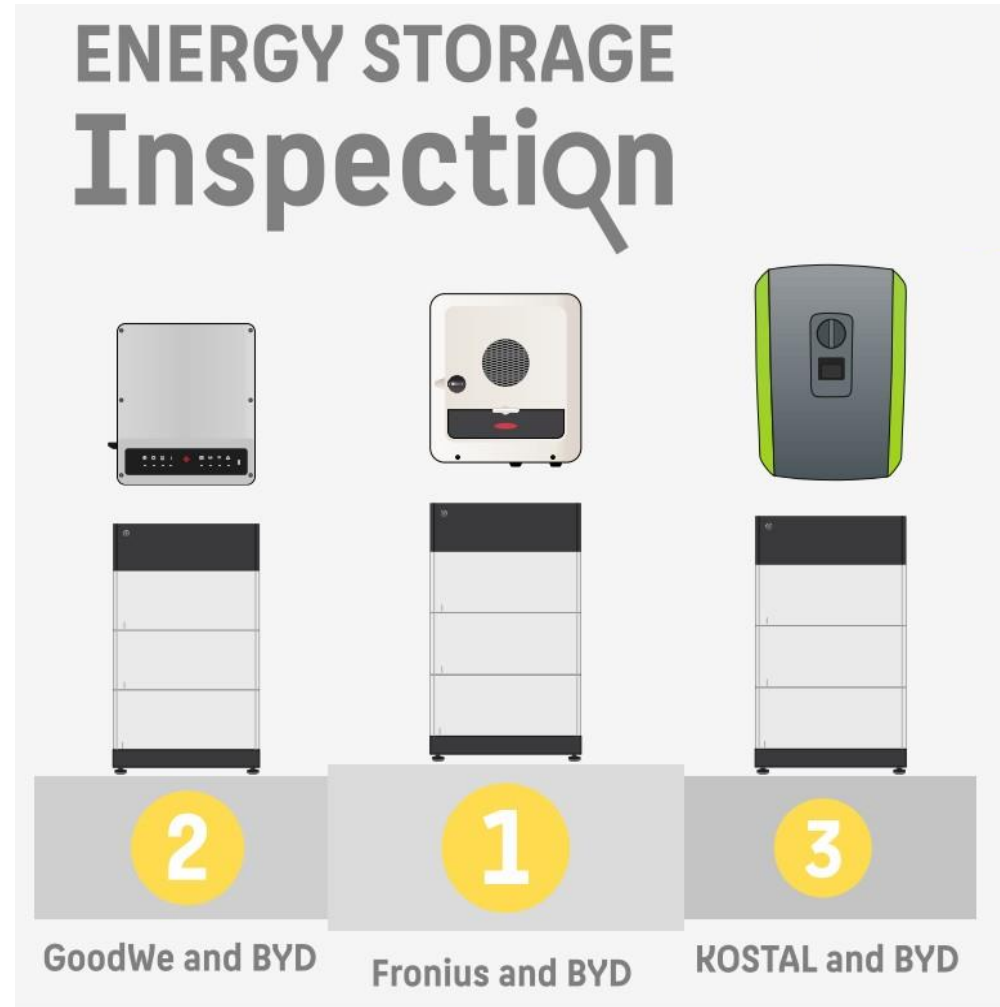

<https://pvspeicher.htw-berlin.de/speicher-inspektion-2021/>



BYD BATTERY-BOX ACHIEVEMENT

BYD leads the European residential battery segment

Solar-plus-storage packages are offered by most solar developers in Europe

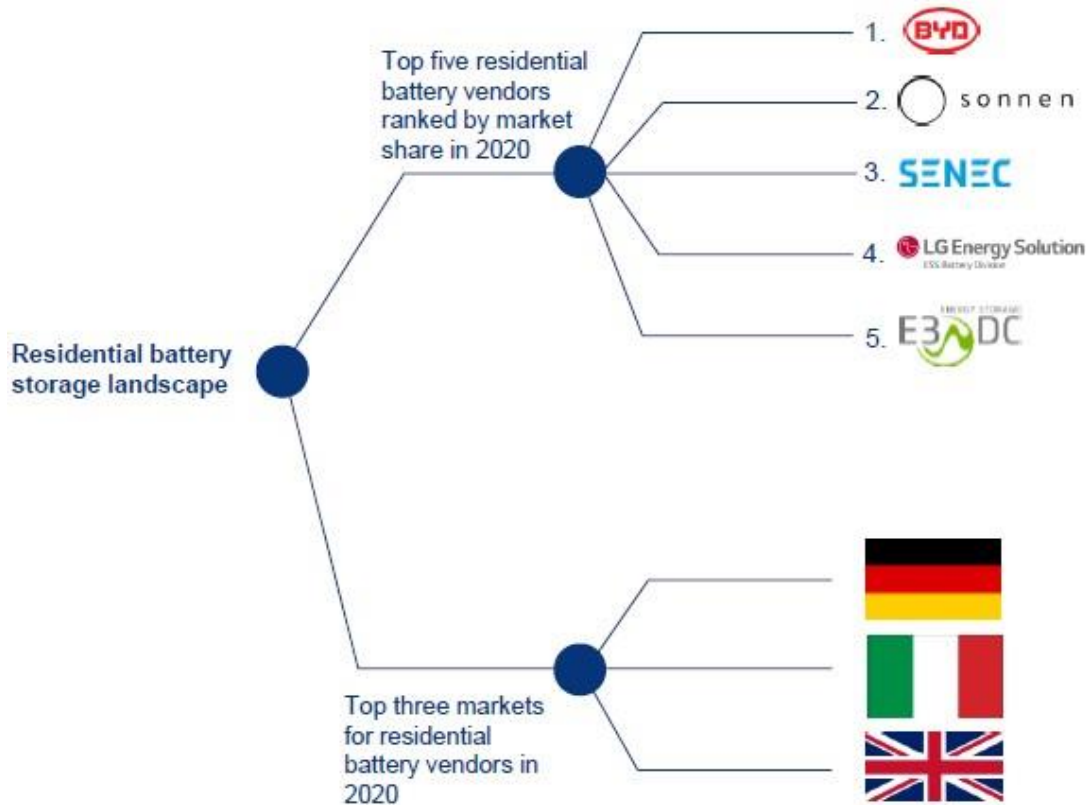

- Based on our data and estimates, **BYD** was leading the European residential energy storage market as of 2020.
- **LFP** battery chemistry currently dominates the residential segment. BYD and Sonnen, the leaders of the European residential storage markets, both work with LFP battery chemistry. With a noted shift and tendency of other energy storage providers to LFP, we expect this battery chemistry's market share to increase in the coming years.
- For the top five listed residential battery vendors in Europe, residential storage is the main market. However, BYD, Sonnen, SENEK and E3DC have all already provided storage technologies for C&I customers.
- Based on our analysis and estimates, most residential battery vendors target Germany as their main market with 60-70% of their installation happening in this country. This focus alerts the potential of overcrowded markets in the near future. Investment outside Germany, Italy and the UK will unlock 14 GWh of distributed storage demand by 2030.

*Rankings are based on both Wood Mackenzie's estimates and collected company data



Source: Wood Mackenzie

4 HIGH ADVANTAGES

HIGH SAFETY



HIGH RELIABILITY



HIGH FLEXIBILITY



HIGH USABILITY



Temp. Range of Decomposition (°C)

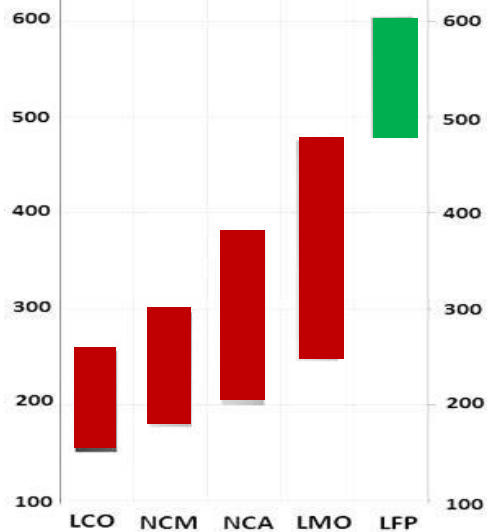

220,000+
Global Installation Experience

7 Years
Tracking Records

90+ Countries
Footprints

0
Fire Accident

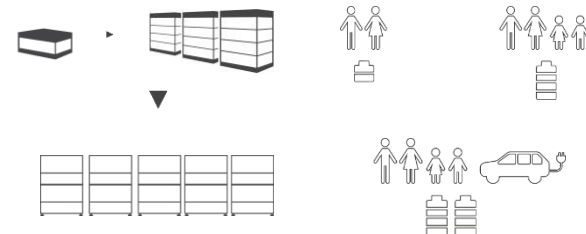

Extension



Installation

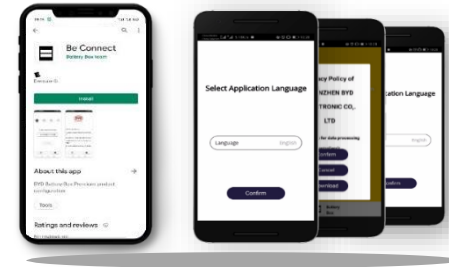

4 BENEFITS For INSTALLERS/RETAILERS

Repeat Purchase



Local Support



Ease of Installation



Flexible packages



System expansion

Alps Power

BYD Service Partner

Technicians in major cities

Brisbane Melbourne Sydney
Adelaide Perth



Internally Wired

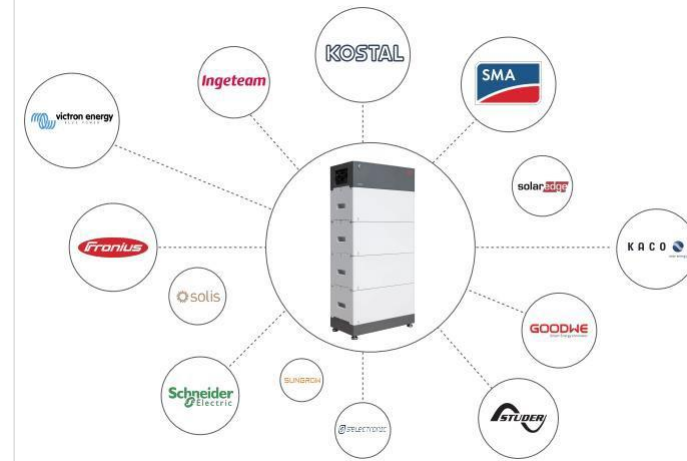

COMPARISON OF LITHIUM BATTERIES

Composition	C-LiFePO ₄		LiMn ₂ O ₄	Lead-acid	NiMH
Safety & Environmental Protection	Safest. No burn/No explode under abuse test. Non-toxicity.	Poor Stability and Insecure. Easy to explode.	Contain heavy metal element. Easy to cause thermal runaway under abuse test, and then fire and explode.	Acceptable safety. Serious pollute environment. Difficulty in recycling.	Poor stability. May catch fire under abuse test.
Cycle life	Best. Capacity over 85% after 1000 times. (Theoretically 2000 times)	< 500 times	300-500 times	≈150 times	1/3 of C-LiFePO ₄
Power Density	Acceptable	Better	Acceptable	Low	Acceptable
Long-term Cost	Most Eco	High	Relatively High	Lifetime cost is higher than C-LiFePO ₄	Relatively High
Effects of Temperature	Excellent. Work normally at -20°C~70°C	Decline when higher than 55°C or lower than -20°C	Decline rapidly when higher than 50°C		Decline rapidly when higher than 55°C or lower than -20°C



BYD Battery-Box Cell Chemistry



CERTIFICATES

广州海关技术
GUANGZHOU CUSTOMS DISTRICT TECHNICAL CENTER

UN38.3 报告
UN38.3 Test Report

样品名称: Battery-Box Premium LVL15.4

Sample Name: Battery-Box Premium LVL15.4

委托单位: 深圳比亚迪电子有限公司

Applicant: SHENZHEN BYD CO., LTD.

CERTIFICATE of Conformity

Registration No.: A50457930 0001

Report No.: 50276446 001

Holder: Shenzhen BYD Electronics Co., Ltd. Room 301 of BYD A-4 Building, No.1 Yan'an Road, Kuichong Street, Dapeng New District Shenzhen 518119 P. R. China

Product: Battery Pack (Battery-Box Premium LVL 15.4)

Identification: Type Designation: Battery Pack (Battery-Box Premium LVL 15.4)

Tested acc. to: EN 61000-6-2:2005, EN 61000-6-3:2007+A1, EN 61000-6-4:2007+A1

Date: 17.01.2020

TÜV Rheinland LGA Products GmbH - Tillystraße 2 - 90431 Nürnberg

CERTIFICATE of Conformity

EC Council Directive 2014/30/EU
Electromagnetic Compatibility

TÜVRheinland

Registration No.: AE 50457930 0001

Report No.: 50276446 001

Holder: Shenzhen BYD Electronics Co., Ltd. Room 301 of BYD A-4 Building, No.1 Yan'an Road, Kuichong Street, Dapeng New District Shenzhen 518119 P. R. China

Product: Battery Pack (Battery-Box Premium LVL 15.4)

Identification: Type Designation: Battery Pack (Battery-Box Premium LVL 15.4)

Tested acc. to: EN 61000-6-2:2005, EN 61000-6-3:2007+A1, EN 61000-6-4:2007+A1

Date: 17.01.2020

TÜV Rheinland LGA Products GmbH - Tillystraße 2 - 90431 Nürnberg

Certification Body: Tongle Lee

技术中心
TECHNOLOGY CENTER

报告
Test Report

样品名称: Battery-Box Premium LVL15.4

Sample Name: Battery-Box Premium LVL15.4

委托单位: 深圳比亚迪电子有限公司

Applicant: SHENZHEN BYD CO., LTD.

HIGHEST INDUSTRY STANDARD

Certified with CE, VDE2510-50, IEC, UL



UN38.3

IEC62619





INSTALLATION TIPS



PREPARATION

BYD Battery-Box Premium Operating Manual

LVS Lite 4.0,8.0,12.0,16.0,20.0,24.0
V1.0



BYD Europe B.V.



Battery-Box Premium Operating Manual

HVS 5.1, 7.7, 10.2, 12.8
HVM 8.3, 11.0, 13.8, 16.6, 19.3, 22.1
A High Voltage Battery System



BYD Smart Device Hungary Kft. V1.7



BE CONNECT

GET IT ON
Google Play

Download on the
App Store



Network Wire Clamp



Pen

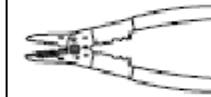

Wire Stripper



Crimper



Phillips Screwdriver Bit



Torque Wrench



Tape Measure



Drill

Installation Manual

“Be Connected” APP

Tools



CHECK THE SCOPE OF BATTERY DELIVERY



LVS

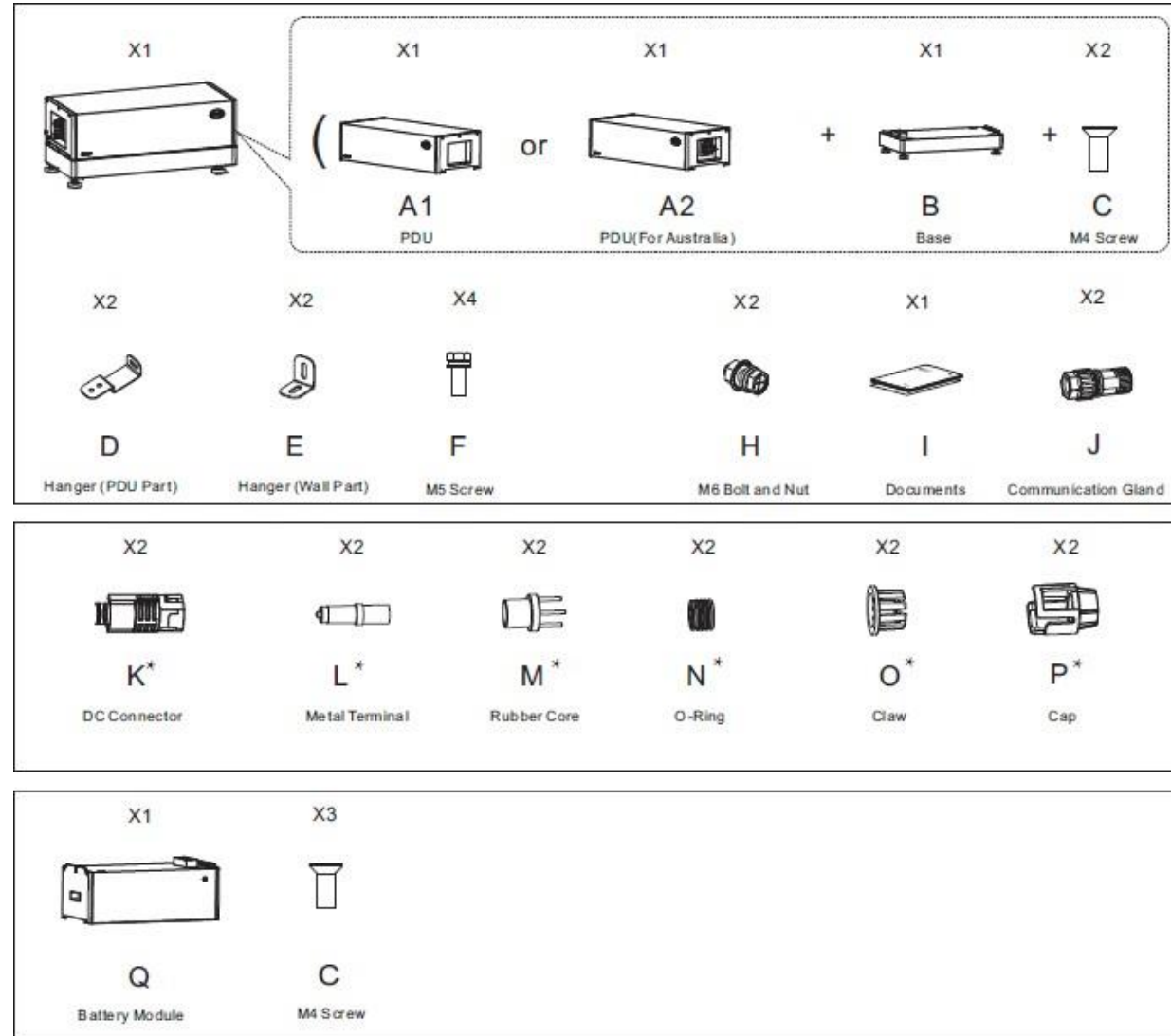

MAKE SURE WHAT IS THE ADDITIONAL REQUIREMENT

5.1.4. Additionally Required Installation Material

x2	x2		x1
			
DC Cable (35mm ² /50mm ² /70mm)	Expansion Anchor Bolt (M8x40)	Cat5 Shield (Metal Shielded RJ45 of Cat5 or higher)	PE with Terminal (terminal,5mm; cable≥10mm ²)

INSTALLATION LOCATION



Max +50° C



Min -10° C



RH. +5% ~ +95%

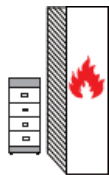
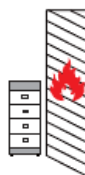
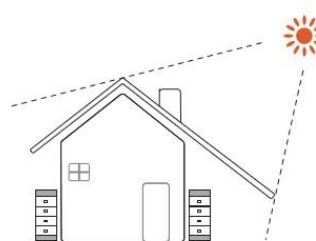

INSTALLATION PROCEDURES

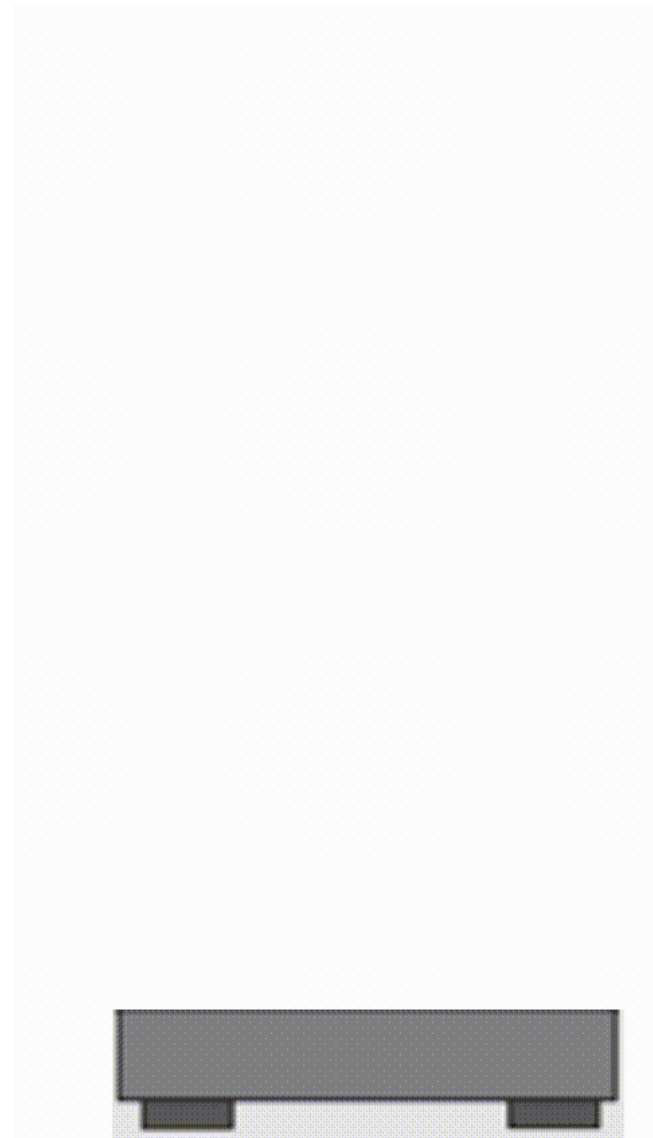
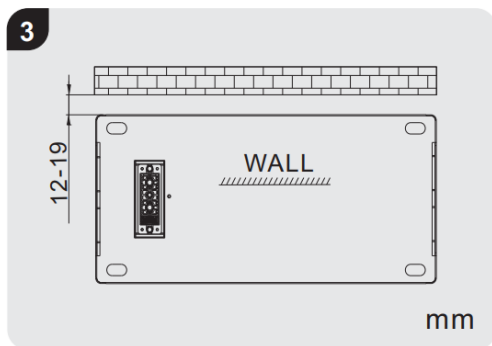
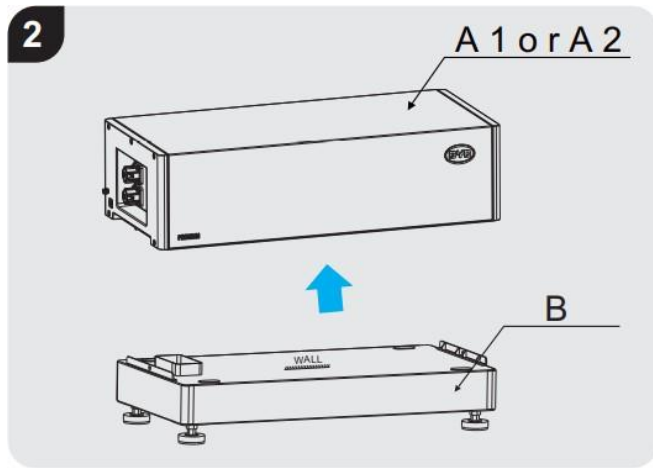
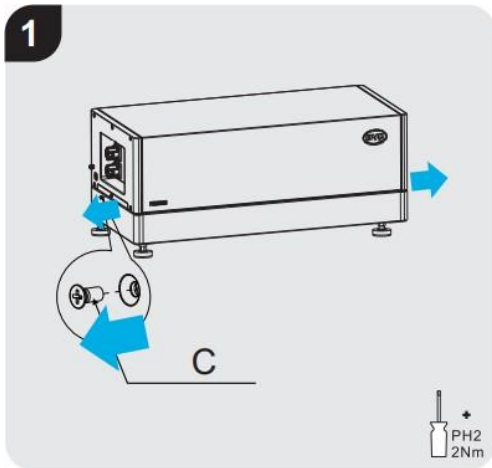

INSTALLATION PROCEDURES

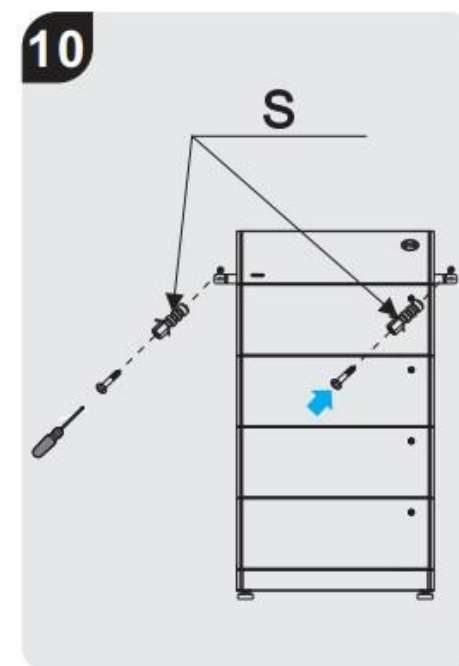
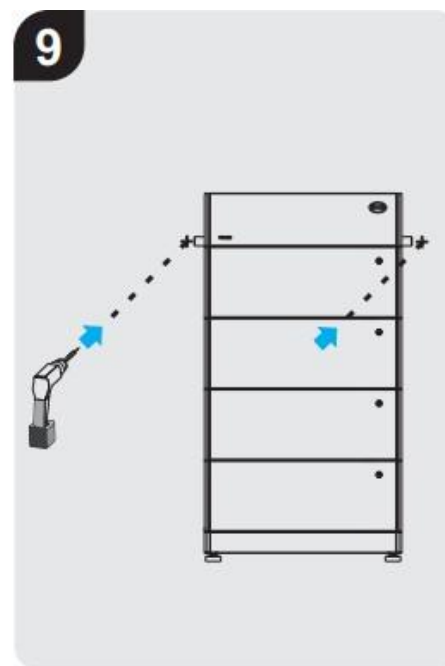
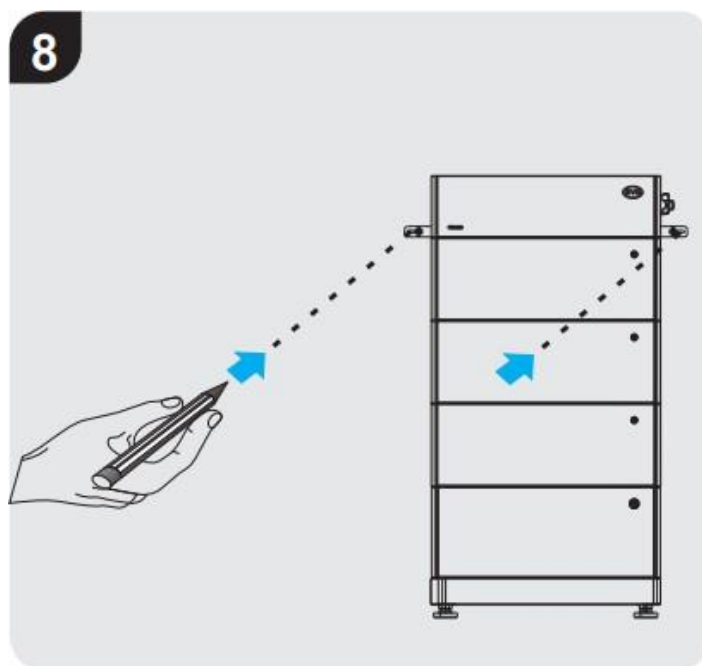
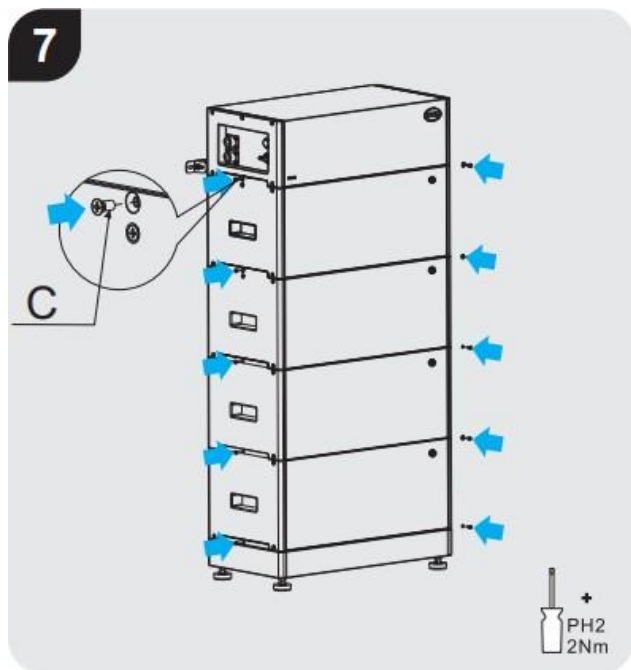

CONNECTION WITH INVERTERS

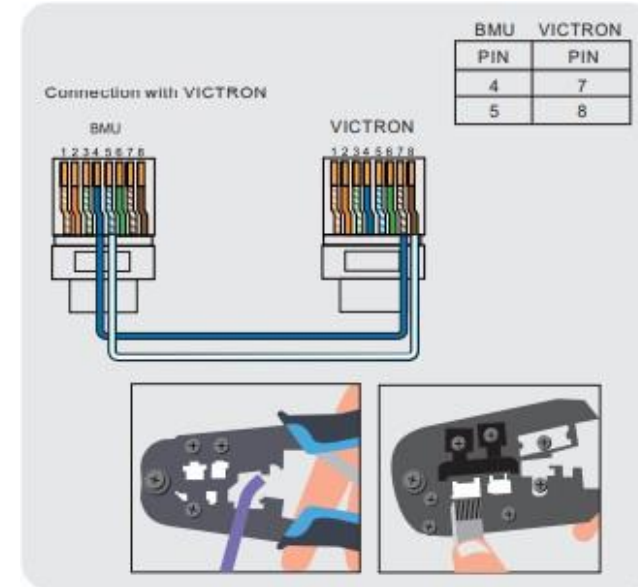
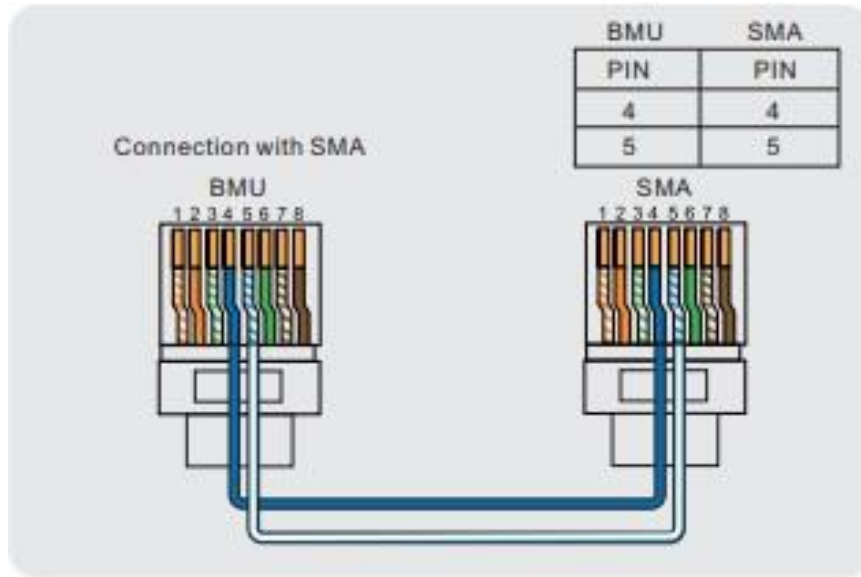

	BMU	SMA	STUDER	VICTRON	SELECTRONIC	SOLAREEDGE	GOODWE	SUNGROW	SCHNEIDER	SOLIS
CAN H	4	4	4	7	1	4	4	4	14	4
CAN L	5	5	5	8	2	5	5	5	12	5



Be Connect 2.0 Configuration Video

CHECK LED LIGHTING

Flashing white and blue alternatively

White ON
 OFF

Blue ON
 OFF

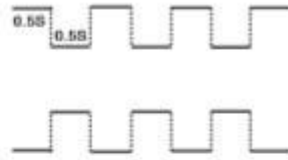

The battery system is initiating.

Glowing white

White ON
 OFF

Blue ON
 OFF



Idle (the battery system is neither charging nor discharging).

Flashing white slowly

White ON
 OFF

Blue ON
 OFF

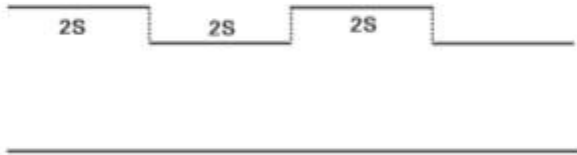

The battery system is charging.

Flashing white quickly

White ON
 OFF

Blue ON
 OFF

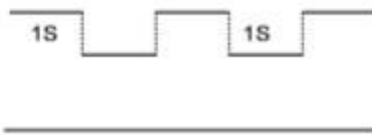

The battery system is discharging.

CHECK LED LIGHTING

Flashing white and glowing blue

White ON
OFF

Blue ON
OFF

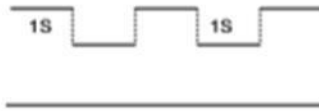

The battery system is discharging, and the SOC of Battery-Box is below 15%.

Flashing white and blue

White ON
OFF

Blue ON
OFF

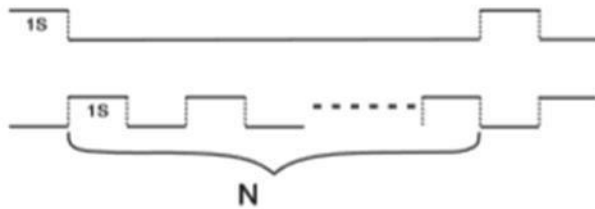

An error has occurred.

An aerial photograph of a mountainous region, likely in a developing area, showing a dense network of roads and rivers. The terrain is rugged and green, with a complex web of roads and waterways. The roads are light-colored, and the rivers are dark, winding through the valleys. The overall scene depicts a challenging environment for infrastructure development.

INFORMATION CHANNEL



6 TIPS BEFORE BUYING A RESIDENTIAL STORAGE SYSTEM

1

Who is the manufacturer of the battery cells inside my storage system?

The battery cells are the key component of the battery and the real value of the battery system. It is important to choose battery manufactures with in-house cell technology and production ability, so that it can ensure the fundamental safety, reliable quality and controllable supply on battery systems.

2

Is my storage system with “Cobalt” inside?

Cobalt is a chemical element found in the Earth's crust only in a chemically combined form, save for small deposits found in alloys of natural meteoric iron. As a rare and expensive chemical element of the battery, cobalt can cause unstable supply & price, as well as pollution. It is widely believed by the industry that LFP battery, without Cobalt element, is environmental friendly and suitable for energy storage systems.

3

Is my storage a real High Voltage product? Or with DC-DC converters?

Using DC/DC converters inside batteries to reach high voltage, might lead to the energy efficiency losses, and higher risk of failure. A true high-voltage product can maximizes the energy use, with minimum loss from energy conversion. And more essentially, it will not have additional failure risk, which is due to the extra conversion components.

A detailed and independent efficiency comparison on different storage systems can be seen in the Storage Inspection analysis by the technical university HTW Berlin.



BYD BATTERY-BOX WEBSITE

4

Do I have flexibility on my storage system, Or is it a bundled choice?

It is important for a battery system to offer flexible options of battery capacity and open choices with various inverters. So you are capable to customize your storage system with the best components available, design your own case and easily upgrade your systems in future. Bundled battery&inverter packages will constrain your project design and extension.

5

Does the battery I am going to buy have reliable tracking records and rich installation experience?

As the product reliability being the key for the user experience, a brand with years of tracking records and extensive experience from real installations in various environments and regions can be of essential advantage. BYD Battery-Box has been installed and proved its reliability in over 200,000 installations worldwide, including over 180,000 in Europe. The installations are covering a wide range of installation environments and scenarios from the Arctic Circle to Central Africa.

6

Does a local technical support need to be considered into battery selection?

A reliable local technicians network is fundamental, so that you can enjoy the quick professional response from the manufacturer locally with easy approach. With more and more energy system providers in the market, it can be of great benefit to choose manufacturers that are truly taking care of the battery from the installation throughout the usage to the end of life and the recycling, which ensures environmental safety and sustainability.



BYD BATTERY-BOX WEBSITE

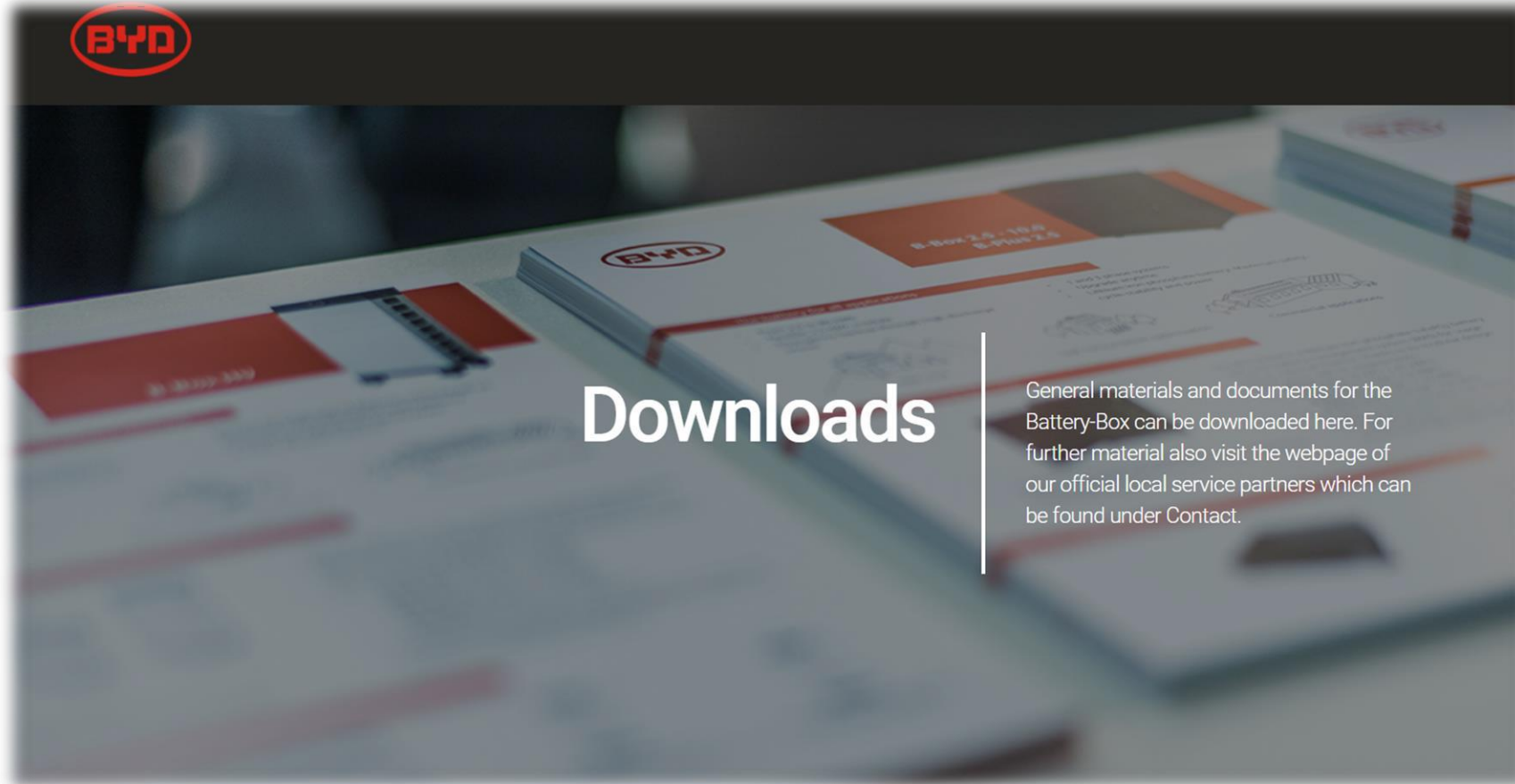

Downloads

General materials and documents for the Battery-Box can be downloaded here. For further material also visit the webpage of our official local service partners which can be found under Contact.

www.bydbatterybox.com



SERVICE TOOL

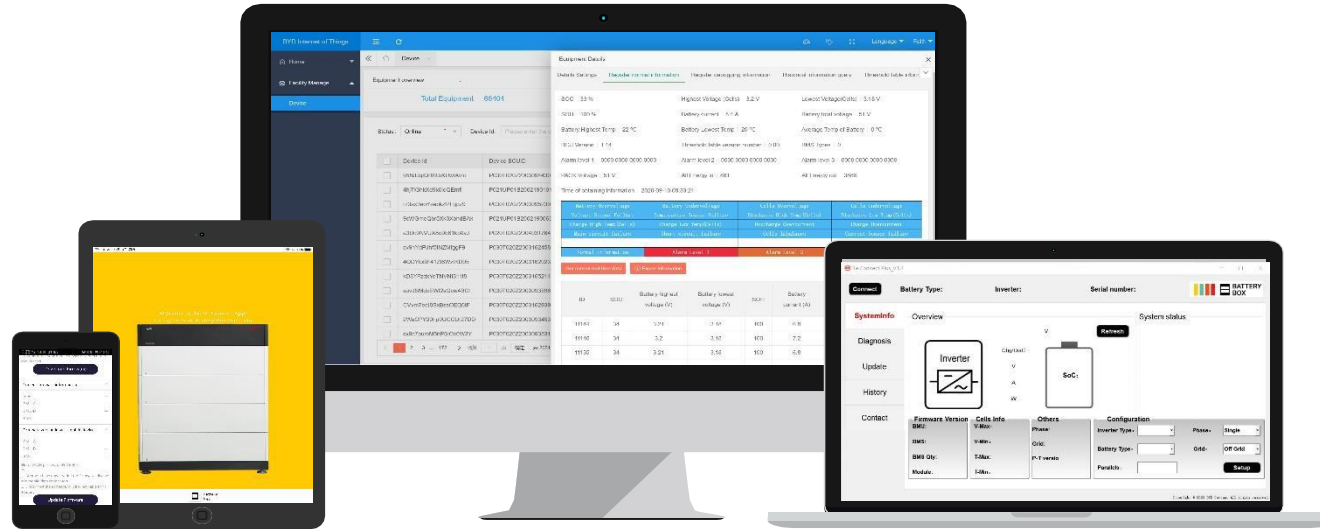

Mobile App(BC)

Be Connect

For Android / Apple systems; cell phones and pad also available.



PC Offline Application(BCP)

Be Connect Plus

Mainly serves offline systems with more functions.



Remote monitoring system(BCM)

Be Connect Monitoring

Remote monitoring and statistical analysis



Be Connect 2.0

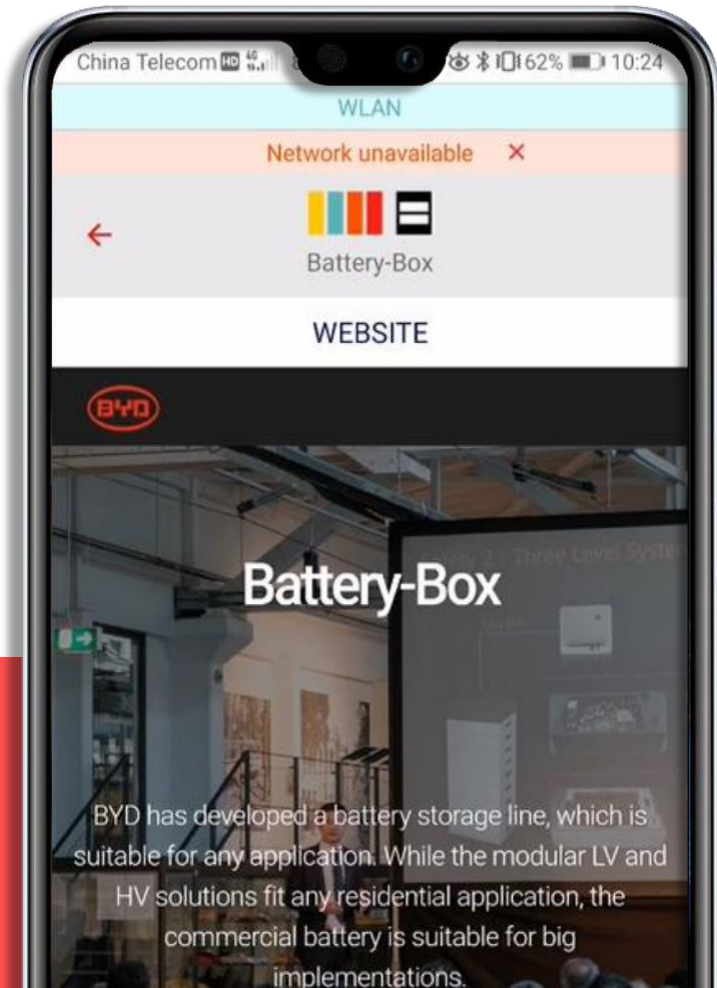

New App Be Connect 2.0

Battery-Box New Mobile App with easier user interface, real time data displaying, event recording and more smart functions.



SERVICE PROCESS

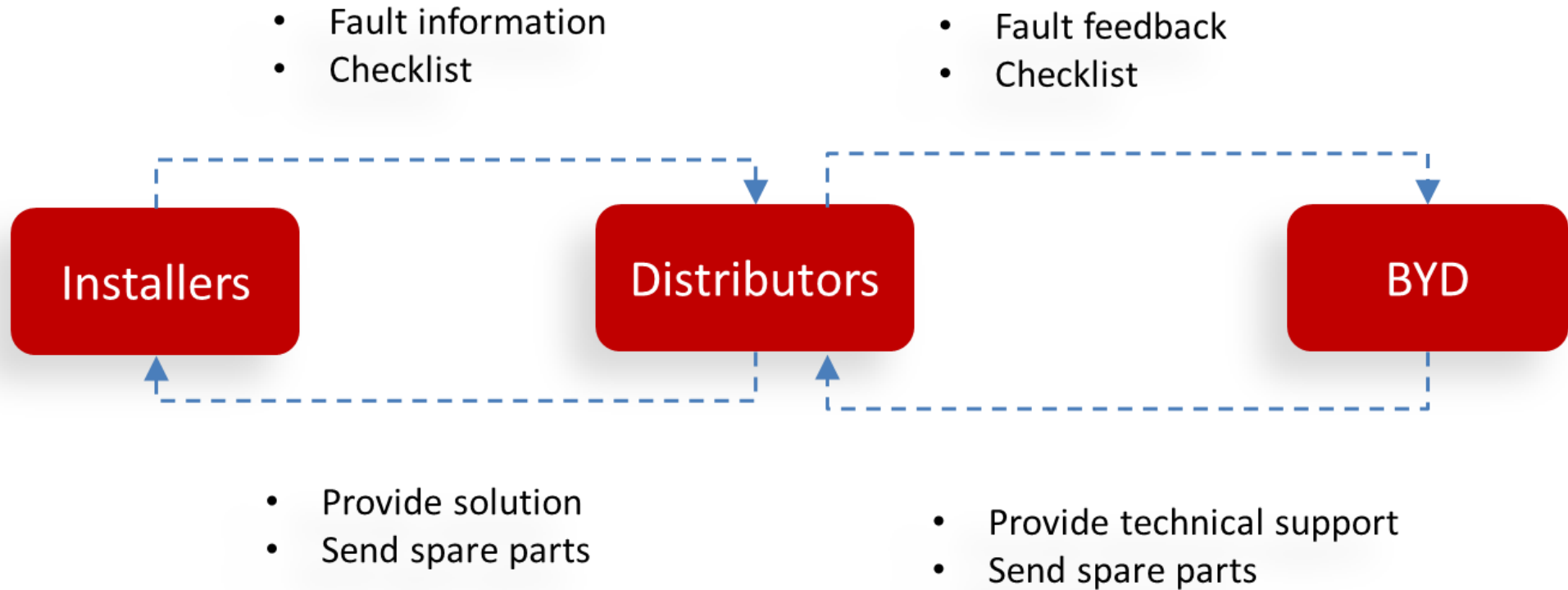

SOCIAL MEDIA & NEWSLETTER – STAY CLOSE WITH US!

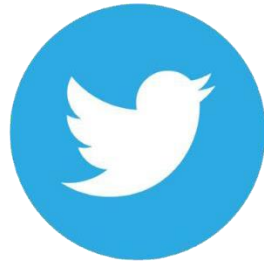

<https://www.linkedin.com/company/byd-battery-box>

https://twitter.com/BYD_BatteryBox

<https://www.facebook.com/BatteryBoxBYD>

Installation Video: <https://www.youtube.com/watch?v=sLJKRbH3f90>



Thanks

Copyright

© Copyright BYD Battery-Box

The content of this presentation (including text, graphics, photos, tables, logos, etc.) and the presentation itself are protected by copyright. They were created by BYD Battery-Box independently.

Any dissemination of the presentation and/or content or parts thereof is only permitted with written permission of BYD Battery-Box. This document and/or parts thereof may not be passed on, modified, published, translated or reproduced, either by photocopies, or by others - in particular by electronic procedures. This reservation also extends to inclusion in or evaluation by databases. Infringements will be prosecuted.

Copyright @BYD Battery-Box 2022